



---

**AWI MANUFACTURING**

---



*Custom*

*Manufacturers*

*of Stainless Steel*

*Products*



# ABOUT US



## About Us

Experience makes the difference...

When you work with **AWI Manufacturing**, you get the benefit of more than 35 years of family experience. We've worked on the road crews and know that you can't afford to have your crew sitting around, waiting for parts. That's why we turn around your quotes and orders faster than anyone in the industry. You don't have to chase us down to get information about your order — we keep you in the loop from day one. We know how hard it can be to keep your project running smoothly, so we do everything we can to make it easy.

Stainless steel parts and tanks you get from AWI Manufacturing are of a consistently superior quality. We've perfected our finishes so there is no rework or delays on the jobsite. Food processing and dairy industry experience has allowed us to refine our parts and make your install easier and faster. Even our packaging is better — we package your parts so it's easy for your install team to find what they need, when they need it. As an installer, you look better to your customers — they'll notice the quality and you'll meet deadlines.

We can also help you with custom requests and challenging circumstances. We know what to look for when you need custom manufacturing and ask you the questions that ensure we get it right the first time. We have knowledge and experience in the food and dairy industry that others do not. As a result, we can help you solve potential issues before they become time wasting problems. Installers, road crews, and our employees have all taught us better ways to do things, saving you time and money.

## A family tradition forged in steel...

AWI Manufacturing was established in 1970, by Art Scherping. Having worked on road crews himself, Art had experienced the hassles caused by poorly manufactured parts. Deciding he could do better, he started custom manufacturing his own — mainly to save himself time and frustration. With seven kids at home, and knowing that working on the road took him away too often, manufacturing stainless steel parts and selling them to the road crews just made good, logical sense. Art's Welding, as it was then known, was born.

As Art's children grew up, they helped to grow the business. Working alongside their father, on install teams, or for machine shops, they honed the skills they would need to provide leadership of the company. In 2004, five of the seven purchased the company and renamed it AWI Manufacturing. A new generation, with solid roots in the industry, is taking AWI Manufacturing to new levels.

Contact AWI Manufacturing today for *Superior Stainless Solutions*.

# TABLE OF CONTENTS



HANGERS.....	1
COMPONENTS .....	7
FLOOR DRAINS .....	13
TANKS .....	17
FLOW PLATES .....	21
ENCLOSURES.....	23
LASER DIVISION.....	28
FACILITY INFORMATION.....	29

# HANGERS



## TUBE SIZE POLYPROPYLENE S.S. HEX HANGERS T-304



**TYPICAL UNFILLED POLYPROPYLENE:**  
 Deflection Temperature (@264psi) 120°F  
 Deflection Temperature (@66psi) 225°F  
 Melting Temperature Approximately 329°F

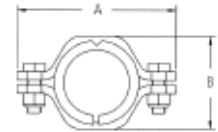

SIZE (TUBE SIZE)	A	B	HANGER W/POLYPROPYLENE COLLAR	BRACKET W/NUTS & BOLTS ONLY	POLYPROPYLENE COLLAR ONLY
			PART #	PART #	PART #
1/2"	2 3/8"	1 1/16"	PVCT-1/2	BRKTSHR-PVCT-.5	PCTS-1/2
3/4"	2 5/8"	1 3/16"	PVCT-3/4	BRKTSHR-PVCT-.75	PCTS-3/4
1"	2 11/16"	1 9/16"	PVCT-1	BRKTSHR-PVCT-1	PCTS-1
1 1/2"	3 5/8"	2 1/8"	PVCT-1.5	BRKTSHR-PVCT-1.5	PCTS-1.5
2"	4 5/16"	2 5/8"	PVCT-2	BRKTSHR-PVCT-2	PCTS-2
2 1/2"	4 7/8"	3 1/8"	PVCT-2.5	BRKTSHR-PVCT-2.5	PCTS-2.5
3"	5 3/8"	3 5/8"	PVCT-3	BRKTSHR-PVCT-3	PCTS-3
4"	6 5/8"	4 5/8"	PVCT-4	BRKTSHR-PVCT-4	PCTS-4
5" *	8 1/16"	5 5/8"	PVCT-5	BRKTSHR-PVCT-5	PCTS-5
6"	9 1/4"	6 5/8"	PVCT-6	BRKTSHR-PVCT-6	PCTS-6
8"	11 3/8"	8 3/4"	PVCT-8	BRKTSET-PVCT-8	PCTS-8
10" *	14 1/2"	10 1/2"	PVCT-10	BRKTSET-PVCT-10	PCTS-10
12" *	16 5/8"	13"	PVCT-12	BRKTSET-PVCT-12	PCTS-12

## PIPE SIZE POLYPROPYLENE S.S. HANGERS T-304

*\*Collar only available in PVC material*

SIZE (PIPE SIZE)	A	B	HANGER W/POLYPROPYLENE COLLAR	BRACKET W/NUTS & BOLTS ONLY	POLYPROPYLENE COLLAR ONLY
			PART #	PART #	PART #
1/2"	2 11/16"	2"	PVCP-1/2	BRKTSHR-PVCT-1	PCPS-1/2
3/4"	2 11/16"	1 9/16"	PVCP-3/4	BRKTSHR-PVCT-1	PCPS-3/4
1"	3 5/8"	2 1/8"	PVCP-1	BRKTSHR-PVCT-1.5	PCPS-1
1 1/4" *	3 5/8"	2 1/4"	PVCP-1.25	BRKTSHR-PVCT-1.5	PCPS-1.25
1 1/2"	4 5/16"	2 5/8"	PVCP-1.5	BRKTSHR-PVCT-2	PCPS-1.5
2"	4 7/8"	3 1/8"	PVCP-2	BRKTSHR-PVCT-2.5	PCPS-2
2 1/2"	4 13/16"	3 1/8"	PVCP-2.5	BRKTSHR-PVCT-3	PCPS-2.5
3"	6"	4 1/4"	PVCP-3	BRKTSHR-PVCP-3	PCPS-3
3 1/2"	6 1/2"	4 3/4"	PVCP-3.5	BRKTSHR-PVCT-4	PCPS-3.5
4"	7 1/2"	5 5/8"	PVCP-4	BRKTSHR-PVCP-4	PCPS-4
5"	8 3/8"	6 3/8"	PVCP-5	BRKTSET-PVCP-5	PCPS-5
6"	9 3/4"	7 3/8"	PVCP-6	BRKTSHR-PVCP-6	PCPS-6
8"	12 1/4"	9 3/8"	PVCP-8	BRKTSET-PVCP-8	PCTS-8
10" *	15 3/8"	11 1/2"	PVCP-10	BRKTSET-PVCP-10	PCTS-10
12" *	17 3/8"	13 7/8"	PVCP-12	BRKTSET-PVCP-12	PCTS-12

## COUPLING

*Half Couplings are available for the above hangers at an additional cost*



SIZE	USE ABOVE PART# AND ADD THE FOLLOWING	HALF COUPLING ONLY
	PART #	PART #
3/8" Pipe Coupling	/PC.38	CPGPIPO3/8
1/2" Pipe Coupling	/PC.50	CPGPIPO1/2
3/8" Rod Coupling	/RC.38	CPGRODO3/8
1/2" Rod Coupling	/RC.50	CPGRODO1/2

## TUBE SIZE HIGH-TEMP S.S. HEX HANGERS T-304



Collars can withstand continuous temperature of 325°F.  
Softening point = 374°F

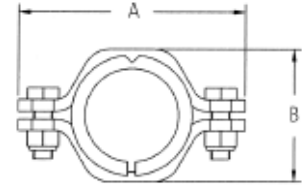

			HANGER W/HIGH-TEMP COLLAR	BRACKET W/NUTS & BOLTS ONLY	HIGH-TEMP COLLAR ONLY
SIZE (TUBE O.D.)	A	B	PART #	PART #	PART #
1/2"	2 3/8"	1 1/16"	HTHTS-1/2	BRKTSHR-PVCT-.5	HTCTS-1/2
3/4"	2 5/8"	1 3/16"	HTHTS-3/4	BRKTSHR-PVCT-.75	HTCTS-3/4
1"	2 11/16"	1 9/16"	HTHTS-1	BRKTSHR-PVCT-1	HTCTS-1
1 1/2"	3 5/8"	2 1/8"	HTHTS-1.5	BRKTSHR-PVCT-1.5	HTCTS-1.5
2"	4 5/16"	2 5/8"	HTHTS-2	BRKTSHR-PVCT-2	HTCTS-2
2 1/2"	4 13/16"	3 1/8"	HTHTS-2.5	BRKTSHR-PVCT-2.5	HTCTS-2.5
3"	5 3/8"	3 5/8"	HTHTS-3	BRKTSHR-PVCT-3	HTCTS-3
4"	6 5/8"	4 5/8"	HTHTS-4	BRKTSHR-PVCT-4	HTCTS-4
6"	9"	6 5/8"	HTHTS-6	BRKTSHR-PVCT-6	HTCTS-6

## PIPE SIZE HIGH-TEMP S.S. HEX HANGERS T-304

			HANGER W/HIGH-TEMP COLLAR	BRACKET W/NUTS & BOLTS ONLY	HIGH-TEMP COLLAR ONLY
SIZE (PIPE SIZE)	A	B	PART #	PART #	PART #
1/2"	2 11/16"	2"	HTHPS-1/2	BRKTSHR-PVCT-1	HTCPS-1/2
3/4"	2 11/16"	1 9/16"	HTHPS-3/4	BRKTSHR-PVCT-1	HTCPS-3/4
1"	3 5/8"	1 7/8"	HTHPS-1	BRKTSHR-PVCT-1.5	HTCPS-1
1 1/2"	4 5/16"	2 5/8"	HTHPS-1.5	BRKTSHR-PVCT-2	HTCPS-1.5
2"	4 7/8"	3 1/8"	HTHPS-2	BRKTSHR-PVCT-2.5	HTCPS-2
2 1/2"	5 3/8"	3 7/8"	HTHPS-2.5	BRKTSHR-PVCT-3	HTCPS-2.5
3"	6 1/16"	4 1/4"	HTHPS-3	BRKTSHR-PVCP-3	HTCPS-3
4"	7 1/2"	5 5/8"	HTHPS-4	BRKTSHR-PVCP-4	HTCPS-4
6"	9 3/4"	7 3/8"	HTHPS-6	BRKTSHR-PVCP-6	HTCPS-6

## HALF COUPLING T-304

Half Couplings are welded to hanger at an additional cost



SIZE	USE ABOVE HANGER PART# AND ADD THE FOLLOWING	HALF COUPLING ONLY
SIZE	PART #	PART #
3/8" Pipe Coupling	/PC.38	CPGPIPO3/8
1/2" Pipe Coupling	/PC.50	CPGPIPO1/2
3/8" Rod Coupling	/RC.38	CPGRODO3/8
1/2" Rod Coupling	/RC.50	CPGRODO1/2

# TUBE SIZE S.S. HEX HANGERS T-304

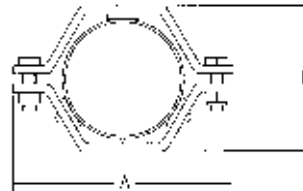

SIZE (TUBE O.D.)	A	B	GROMMET QTY & SIZE	ALCRYN GROMMET HANGERS	VITON GROMMET HANGERS	BRACKET W/NUTS & BOLTS ONLY
				PART #	PART #	PART #
1/4"	2 1/4"	7/8"	1ea. — 1/8, 1/4"	RGT-.25	RGTV-1/4	BRKTSET-RGT-.25
3/8"	2 1/4"	7/8"	2 — 1/8"	RGT-3/8	RGTV-3/8	BRKTSET-RGT-.25
1/2"	3 5/8"	2 1/8"	3 — 5/8"	RGT-1/2	RGTV-1/2	BRKTSHR-RGT-1.5
3/4"	3 5/8"	2 1/8"	3 — 1/2"	RGT-3/4	RGTV-3/4	BRKTSHR-RGT-1.5
1"	3 5/8"	2 1/8"	3 — 3/8"	RGT-1	RGTV-1	BRKTSHR-RGT-1.5
1 1/4"	3 5/8"	2 1/8"	3 — 1/4"	RGT-1.25	RGTV-1.25	BRKTSHR-RGT-1.5
1 1/2"	3 5/8"	2 1/8"	3 — 1/8"	RGT-1.5	RGTV-1.5	BRKTSHR-RGT-1.5
2"	4 5/16"	2 5/8"	3 — 1/8"	RGT-2	RGTV-2	BRKTSHR-RGT-2
2 1/2"	4 7/8"	3 1/8"	3 — 1/8"	RGT-2.5	RGTV-2.5	BRKTSHR-RGT-2.5
3"	5 3/8"	3 5/8"	3 — 1/8"	RGT-3	RGTV-3	BRKTSHR-RGT-3
4"	6 9/16"	4 3/4"	4 — 1/8"	RGT-4	RGTV-4	BRKTSHR-RGT-4
5"	8"	5 5/8"	4 — 1/8"	RGT-5	RGTV-5	BRKTSHR-RGT-5
6"	9"	6 5/8"	5 — 1/8"	RGT-6	RGTV-6	BRKTSHR-RGT-6
8"	11 1/4"	8 3/4"	5 — 1/8"	RGT-8	RGTV-8	BRKTSET-RGT-8
10"	14 1/2"	10 1/2"	6 — 1/8"	RGT-10	RGTV-10	BRKTSET-RGT-10
12"	16 3/4"	12 5/8"	6 — 1/8"	RGT-12	RGTV-12	BRKTSET-RGT-12
14"	19"	14 3/4"	6 — 1/8"	RGT-14	RGTV-14	BRKTSET-RGT-14

## COUPLING

Couplings are available for the above hangers at an additional cost each



SIZE	USE ABOVE PART# AND ADD THE FOLLOWING	HALF COUPLING ONLY PART #
3/8" Pipe Coupling	/PC.38	CPGPIPO3/8
1/2" Pipe Coupling	/PC.50	CPGPIPO1/2
3/8" Rod Coupling	/RC.38	CPGRODO3/8
1/2" Rod Coupling	/RC.50	CPGRODO1/2

## ALCRYN & VITON GROMMETS



Alcryn Temperature Range  
40°F to 257°F, 3/4" diameter  
with 5/16" pin



Viton Temperature Range 73°F to  
392°F, 3/4" diameter with 5/16" pin

THICKNESS	ALCRYN GROMMETS	VITON GROMMETS
	PART #	PART #
1/8" Grommets	RGO-1/8	RGOV-1/8
1/4" Grommets	RGO-1/4	RGOV-1/4
3/8" Grommets	RGO-3/8	RGOV-3/8
1/2" Grommets	RGO-1/2	RGOV-1/2
5/8" Grommets	RGO-5/8	RGOV-5/8

## PIPE SIZE S.S. HEX HANGERS T-304

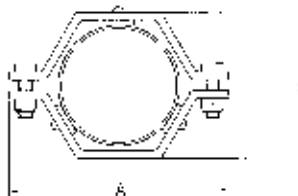

SIZE (PIPE SIZE)	A	B	GROMMET QTY & SIZE	ALCRYN GROMMET HANGERS	VITON GROMMET HANGERS	BRACKET W/NUTS & BOLTS ONLY
				PART #	PART #	PART #
1/2"	3 5/8"	2 1/4"	3 - 1/2"	RGP-1/2	RGPV-1/2	BRKTSHR-RGT-1.5
3/4"	3 5/8"	2 3/16"	3 - 3/8"	RGP-3/4	RGPV-3/4	BRKTSHR-RGT-1.5
1"	3 5/8"	2 1/8"	3 - 1/4"	RGP-1	RGPV-1	BRKTSHR-RGT-1.5
1 1/4"	4 5/16"	2 3/4"	3 - 3/8"	RGP-1.25	RGPV-1.25	BRKTSHR-RGT-2
1 1/2"	4 5/16"	2 13/16"	3 - 1/4"	RGP-1.5	RGPV-1.5	BRKTSHR-RGT-2
2"	4 7/8"	3 1/4"	3 - 1/4"	RGP-2	RGPV-2	BRKTSHR-RGT-2.5
2 1/2"	5 3/8"	3 7/8"	3 - 1/4"	RGP-2.5	RGPV-2.5	BRKTSHR-RGT-3
3"	6 1/16"	4 5/16"	4 - 1/8"	RGP-3	RGPV-3	BRKTSHR-RGP-3
4"	7 7/16"	5 1/8"	4 - 1/8"	RGP-4	RGPV-4	BRKTSHR-RGP-4
5"	9"	6 3/8"	5 - 1/8"	RGP-5	RGPV-5	BRKTSHR-RGP-5
6"	9 7/8"	7 1/8"	5 - 1/8"	RGP-6	RGPV-6	BRKTSHR-RGP-6
8"	12 1/4"	9 3/8"	5 - 1/8"	RGP-8	RGPV-8	BRKTSET-RGP-8
10"	15 3/8"	11 3/8"	6 - 1/8"	RGP-10	RGPV-10	BRKTSET-RGP-10
12"	17 3/8"	13 11/16"	6 - 1/8"	RGP-12	RGPV-12	BRKTSET-RGP-12

## COUPLING

Couplings are available for the above hangers at an additional cost each



SIZE	USE ABOVE PART# AND ADD THE FOLLOWING	HALF COUPLING ONLY
SIZE	PART #	PART #
3/8" Pipe Coupling	/PC.38	CPGPIPO3/8
1/2" Pipe Coupling	/PC.50	CPGPIPO1/2
3/8" Rod Coupling	/RC.38	CPGRODO3/8
1/2" Rod Coupling	/RC.50	CPGRODO1/2

## ALCRYN & VITON GROMMETS



Alcryn Temperature Range  
40°F to 257°F, 3/4" diameter  
with 5/16" pin



Viton Temperature Range 73°F to  
392°F, 3/4" diameter with 5/16" pin

THICKNESS	ALCRYN GROMMETS	VITON GROMMETS
	PART #	PART #
1/8" Grommets	RGO-1/8	RGOV-1/8
1/4" Grommets	RGO-1/4	RGOV-1/4
3/8" Grommets	RGO-3/8	RGOV-3/8
1/2" Grommets	RGO-1/2	RGOV-1/2
5/8" Grommets	RGO-5/8	RGOV-5/8



## TUBE SIZE S.S. U-BOLT HANGERS T-304

Other sizes available upon request



			<i>U-BOLT HANGERS</i>	<i>BAR ONLY</i>	<i>U BOLT ONLY</i>
<b>U-BOLT SIZE</b>	<b>PLATE SIZE</b>	<b>ROD SIZE</b>	<b>PART #</b>	<b>PART #</b>	<b>PART #</b>
1/2"	3/16" x 3/4" x 1 7/8"	1/4" x 3 7/8"	UT-1/2	UT-PLATE-1/2	UTO-1/2
3/4"	3/16" x 3/4" x 1 7/8"	1/4" x 3 7/8"	UT-3/4	UT-PLATE-3/4	UTO-3/4
1"	3/16" x 3/4" x 2 1/8"	1/4" x 4 3/8"	UT-1 / UP-3/4	UT-PLATE-1	UTO-1
1 1/2"	1/4" x 1" x 2 7/8"	5/16"	UT-1.5	UT-PLATE-1.5	UTO-1.5
2"	1/4" x 1" x 3 3/8"	5/16"	UT-2	UT-PLATE-2	UTO-2
2 1/2"	1/4" x 1" x 3 7/8"	5/16"	UT-2.5	UT-PLATE-2.5	UTO-2.5
3"	1/4" x 1" x 4 3/8"	5/16"	UT-3	UT-PLATE-3	UTO-3
4"	1/4" x 1" x 5 1/4"	5/16"	UT-4	UT-PLATE-4	UTO-4
5"	1/4" x 1 1/4" x 6 1/2"	3/8"	UT-5	UT-PLATE-5	UTO-5
6"	3/8" x 1 1/2" x 7 1/2"	3/8"	UT-6	UT-PLATE-6	UTO-6
8"	3/8" x 1 1/2" x 9 1/2"	3/8"	UT-8	UT-PLATE-8	UTO-8
10"	3/8" x 2" x 11 1/2"	3/8"	UT-10	UT-PLATE-10	UTO-10
12"	3/8" x 2" x 13 1/2"	3/8"	UT-12	UT-PLATE-12	UTO-12

## PIPE SIZE S.S. U-BOLT HANGERS T-304

			<i>U-BOLT HANGERS</i>	<i>BAR ONLY</i>	<i>U BOLT ONLY</i>
<b>U-BOLT SIZE</b>	<b>PLATE SIZE</b>	<b>ROD SIZE</b>	<b>PART #</b>	<b>PART #</b>	<b>PART #</b>
1/2"	3/16" x 3/4" x 1 7/8"	1/4"	UP-1/2	UP-PLATE-1/2	UPO-1/2
3/4"	3/16" x 3/4" x 2 1/8"	1/4"	UP-3/4	UT-PLATE-1	UTO-1
1"	3/16" x 3/4" x 2 1/2"	1/4"	UP-1	UP-PLATE-1	UPO-1
1 1/4"	1/4" x 1" x 2 7/8"	5/16"	UP-1.25	UT-PLATE-1.5	UPO-1.25
1 1/2"	1/4" x 1" x 3 1/8"	5/16"	UP-1.5	UP-PLATE-1.5	UPO-1.5
2"	1/4" x 1" x 3 5/8"	5/16"	UP-2	UP-PLATE-2	UPO-2
2 1/2"	1/4" x 1" x 4 5/32"	5/16"	UP-2.5	UP-PLATE-2.5	UPO-2.5
3"	1/4" x 1 1/4" x 5 1/8"	3/8"	UP-3	UP-PLATE-3	UPO-3
4"	1/4" x 1 1/4" x 6 1/8"	3/8"	UP-4	UP-PLATE-4	UPO-4
5"	3/8" x 1 1/2" x 7 1/16"	3/8"	UP-5	UP-PLATE-5	UPO-5
6"	3/8" x 1 1/2" x 8 1/4"	3/8"	UP-6	UP-PLATE-6	UPO-6
8"	3/8" x 2" x 10 1/8"	3/8"	UP-8	UP-PLATE-8	UPO-8
10"	3/8" x 2" x 12 1/4"	3/8"	UP-10	UP-PLATE-10	UPO-10
12"*	1/4" x 1 1/2" x 14 5/8"	1/2"	UP-12	UP-PLATE-12	UPO-12

\*Angle bar.

# COMPONENTS



# T-304 S.S. DISHED WALL FLANGES

Other sizes available upon request for all Wall Flange styles

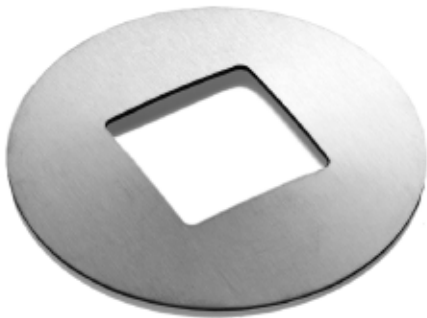

## SQUARE S.S. WALL FLANGES (16 GA)

SIZE	PART #
2" ID x 5" OD	WFSQ-2
1 1/2" ID x 5" OD	WFSQ-1.5

## TUBE SIZE S.S. SPLIT WALL FLANGES (16 GA)

SIZE	PART #
1" x 5"	WFT-1 SPLIT
1.5" x 5"	WFT-1.5 SPLIT
2" x 5"	WFT-2 SPLIT
2.5" x 5"	WFT-2.5 SPLIT
3" x 6"	WFT-3 SPLIT
4" x 7"	WFT-4 SPLIT



## TUBE SIZE S.S. WALL FLANGES (16 GA)

SIZE	PART #
1/2" x 3"	WFT-1/2X3
1/2" x 5"	WFT-1/2
3/4" x 3"	WFT-3/4X3
3/4" x 5"	WFT-3/4
1" x 3"	WFT-1X3
1" x 5"	WFT-1
1 1/2" x 5"	WFT-1.5
2" x 5"	WFT-2
2 1/2" x 5"	WFT-2.5
3" x 6"	WFT-3
4" x 7"	WFT-4
5" x 8"	WFT-5
6" x 10"	WFT-6
8" x 12"	WFT-8
10" x 14"	WFT-10
12" x 16"	WFT-12

## PIPE SIZE S.S. WALL FLANGES (16 GA)

SIZE	PART #
.84" x 5"	WFP-1/2
1.05" x 5"	WFP-3/4
1.315" x 5"	WFP-1
1.66" x 5"	WFP-1.25
1.9" x 5"	WFP-1.5
2.375" x 5"	WFP-2
2.875" x 5"	WFP-2.5
3.5" x 6"	WFP-3
4" x 6"	WFT-4
4.5" x 7"	WFP-4
5.563" x 9"	WFP-5
6.625" x 10"	WFP-6
8.625" x 12"	WFP-8
10.75" x 14.75"	WFP-10
12.75" x 16.75"	WFP-12

## T-304 S.S. PIPE SADDLES

Other sizes available upon request



### ***T-304 S.S. SCH 10 PIPE SADDLES***

SIZE	PART #
1"	PSAD10-1
1 1/4"	PSAD10-1.25
1 1/2"	PSAD10-1.5
2"	PSAD10-2
3"	PSAD10-3

### ***T-304 S.S. SCH 40 PIPE SADDLES***

SIZE	PART #
1 "	PSAD40-1
1 1/4"	PSAD40-1.25
1 1/2"	PSAD40-1.5
2"	PSAD40-2
3"	PSAD40-3

### ***T-304 S.S. TUBE SIZE SADDLES***

SIZE	PART #
1 1/2"	PSADT-1.5
2"	PSADT-2

## T-304 S.S. ADJUSTABLE BAND CLAMPS (19 GA X 1" WIDE)

State O.D. Measurement of pipe or tube and material thickness to be banded



SIZE	PART #
5" - 36"	CLAMP5-36
37" - 48"	CLAMP37-48
49" - 60"	CLAMP49-60
61" -85"	CLAMP61-85

## T-304 S.S. ADJUSTABLE LEGS



SIZE	WEIGHT CAPACITY	PART #
1 1/4" Sch 10 x 4" long	2,000 lbs	LEG-1.25X4
1 1/2" Sch 10 x 6" long	4,500 lbs	LEG-1.5X6
1 1/2" Sch 10 x 12" long	4,500 lbs	LEG-1.5X12
2" Sch 40 x 6" long	5,500 lbs	LEG-2X6
2 1/2" Sch 40 x 6" long	7,000 lbs	LEG-2.5X6
3" Sch 40 x 6" long	7,500 lbs	LEG-3X6
4" Sch 40 x 6" long	8,500 lbs	LEG-4X6
2" Square x 6" long 11ga	4,500 lbs	LEGSQ-2

## T-304 S.S. WALL PLATE AND LEG PADS

Other sizes available upon request



### WALL PLATES

SIZE	PART #
1/4" x 2" x 6"	WP1/4-26
1/4" x 2" x 7"	WP1/4-27
1/4" x 2 1/2" x 6"	WP1/4-2.56
1/4" x 2 1/2" x 7"	WP1/4-2.57
1/4" x 3" x 3"	WP1/4-33
1/4" x 4" x 4"	WP1/4-44
1/4" x 6" x 6"	WP1/4-66
1/4" x 8" x 8"	WP1/4-88
3/8" x 4" x 4"	WP3/8-44
3/8" x 6" x 6"	WP3/8-66

### ADDITIONAL CHARGE FOR HOLES

SIZE	ADD TO ABOVE WALL PLATE PART #
1 Hole	-1H
2 Holes	-2H
3 Holes	-3H
4 Holes	-4H

### LEG PADS

Please call to discuss sizes

## T-304 S.S. RINGS (16GA)

Also available in 14ga upon request

Other sizes available upon request



SIZE	PART #
1/2" ID x 4" OD	RING1/24
1" ID x 1 1/2" OD	RING11.5
1" ID x 2" OD	RING12
1" ID x 2 1/2" OD	RING12.5
1" ID x 3" OD	RING13
1 1/2" ID x 2" OD	RING1.52
1 1/2" ID x 2 1/2" OD	RING1.52.5
1 1/2" ID x 3" OD	RING1.53
2" ID x 2 1/2" OD	RING22.5
2" ID x 3" OD	RING23
2" ID x 4" OD	RING24
2 1/2" ID x 3" OD	RING2.53
2 1/2" ID x 3 1/2" OD	RING2.53.5
2 1/2" ID x 4" OD	RING2.54
3" ID x 4" OD	RING34
3" ID x 4 1/2" OD	RING34.5
4" ID x 5" OD	RING45
4" ID x 6" OD	RING46

# T-304 S.S. END CAPS (FLAT)

Other size end caps available upon request

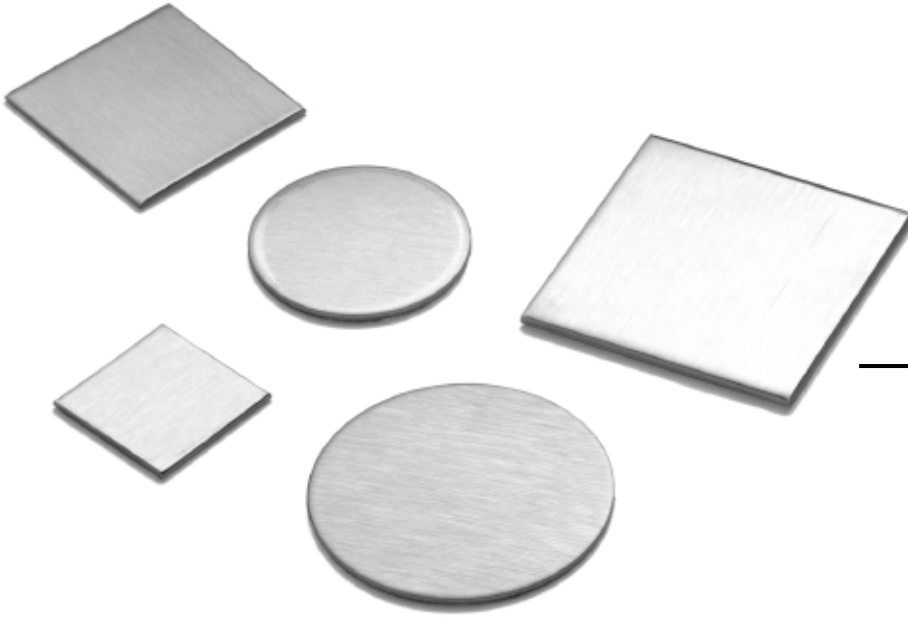

## TUBE SIZE

SIZE	PART #
1/2"	ECT-1/2
3/4"	ECT-3/4
1"	ECT-1
1 1/2"	ECT-1.5
2"	ECT-2
2 1/2"	ECT-2.5
3"	ECT-3
4"	ECT-4
5"	ECT-5
6"	ECT-6

## PIPE SIZE

SIZE	PART #
1/2"	ECP-1/2
3/4"	ECP-3/4
1"	ECP-1
1 1/4"	ECP-1.25
1 1/2"	ECP-1.5
2"	ECP-2
2 1/2"	ECP-2.5
3"	ECP-3
4"	ECP-4

## SQUARE END CAPS

SIZE	PART #
1"	ECSQ-1
1 1/2"	ECSQ-1.5
2"	ECSQ-2
2 1/2"	ECSQ-2.5
3"	ECSQ-3
4"	ECSQ-4

### ADDITIONAL CHARGE ADDED TO END CAP

DESCRIPTION	ADD TO END CAP PART #
Dished end cap	- DISHED
Weld 1/2" nut to end cap	- W/.5NUT

# FLOOR DRAINS

- Drain top constructed of 1/2" x 12" x 12" S.S. plate
- 12 ga. x 10 3/4" dia. x 6" deep body
- 4" long outlet extension



*Optional bar grate cover*



*Perforated S.S. basket with lift handle*



*1/2" thick S.S. cover plate*



## SANITARY FLOOR DRAINS

### Complete Stainless Steel Floor Drains

Stainless steel floor drains from AWI Manufacturing are created with a sanitary design for Food Equipment and Dairy Industry applications. Our complete drainage systems are built to last, eliminate build-up and hold up to heavy equipment traffic. Constructed from 1/2" thick stainless steel, the top flange can be square or round depending on customer preference. Standard design sizes are available or we can custom design and manufacture any stainless steel drain to your specifications.

- ▶ 12 Ga single piece, seamless construction on body
- ▶ T-304 stainless construction
- ▶ Withstands heavy equipment traffic
- ▶ Standard size 4" Sch.-10 outlet
- ▶ Other outlet sizes available
- ▶ Glass bead finish
- ▶ Outer cement ring
- ▶ USDA Approved

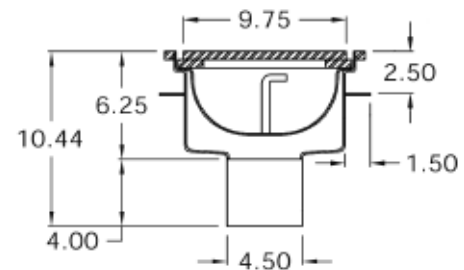
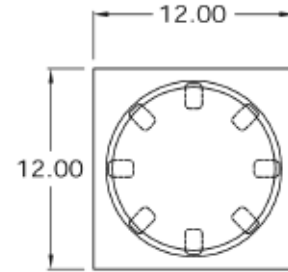

### Floor Drain Bodies

- ▶ Standard size 4" Sch.-10 outlet (Sch.-40 optional)
- ▶ Other bodies available
  - Side outlet
  - Shallow body (low profile)
  - Cleanout attached
  - Side coupling for trap primer
  - Membrane ring
- ▶ Tamper proof option available upon request



Standard floor drain body

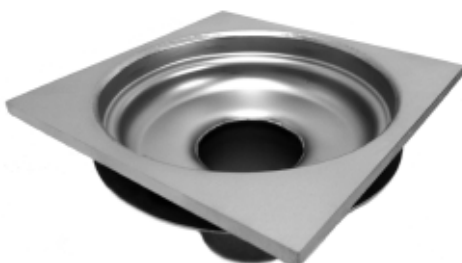

Low profile drain

## P-Trap & Cleanout Assembly

Stainless steel floor drains and P-Traps by AWI Manufacturing are designed for Food and Dairy Industry applications. P-Traps are designed to flush waste away while preventing backflow of noxious fumes and gases from the sewer line. Drains can be equipped with a trap and cleanout, or a trap by itself. The trap and cleanout allows for cleaning down line.

- ▶ Sch. 10 elbows and pipe
- ▶ 2" tube cleanout from drain to discharge
- ▶ 1 1/2" internal plug in drain to prevent backflow
- ▶ 12 ga. cement ring
- ▶ Standard 4" size outlet
- ▶ Other sizes available (3", 6", 8" & 10")

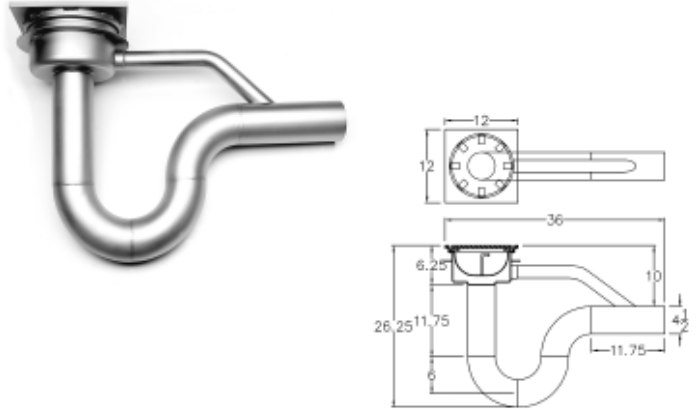
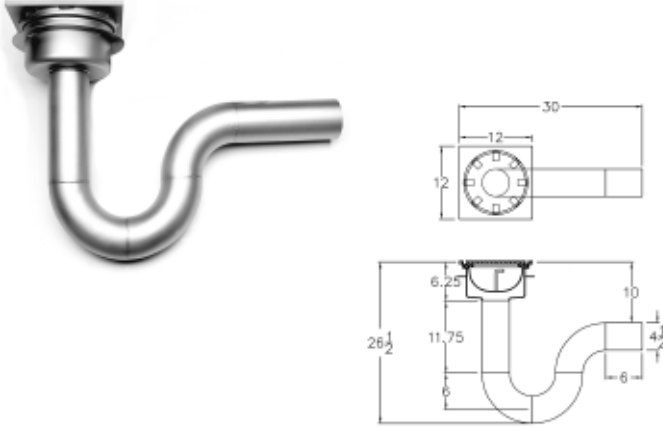

### COVER PLATE OPTIONS

- ▶ O-ring sealed cover plate (odor prevention)
- ▶ Tamper proof option available upon request



Standard cover plate



Side notch



Center hole



Round bar grate



Slotted



Standard



Slotted sides



Perforated sides

**HUB DRAINS**

- ▶ T-304
- ▶ Glass Bead finish
- ▶ Size as specified



**MEDIUM DUTY FLOOR DRAIN**

- ▶ 8" diameter
- ▶ 12 Ga. single piece, seamless construction on body
- ▶ T304 stainless construction
- ▶ Outlet sizes available (2", 3", 4")
- ▶ Outer cement ring
- ▶ Glassbead finish
- ▶ Perforated basket



**NO-HUB CLEANOUTS**

- ▶ Standard 4" & 6" available
- ▶ T304 & T316 construction
- ▶ PVC plug
- ▶ O-Ring sealed surface

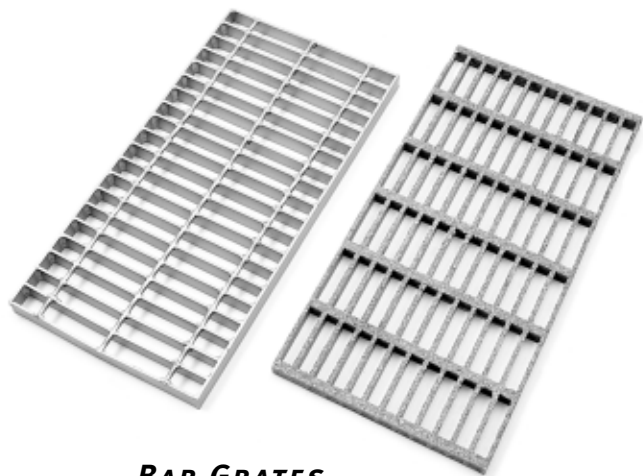

**BAR GRATES**

- ▶ 12 ga. T-304 construction
- ▶ Outlet size as specified
- ▶ Cement anchors on side of trench drain to embed in concrete
- ▶ 1/8" per foot slope
- ▶ Cover options
  - Slotted 1/2" cover plate
  - Chemgrate or stainless steel bar grating
  - Perforated 10 ga. or 12 ga. cover for lighter duty application



**TRENCH DRAINS**



# TANKS

## *ROUND RAISED BRIDGE BALANCE TANK*



- ▶ Custom designed tanks
- ▶ Legs provided with adjustable ball feet
- ▶ Fabricated to meet 3A sanitary standards
- ▶ Removable-locking position cover
- ▶ T-304 or T-316

- ▶ Raised bridge to meet current PMO standards
- ▶ One piece hinging cover with inspection port
- ▶ 3/4" radius corners for easy cleaning
- ▶ #4 finish inside and out

---

## *RECTANGLE BALANCE TANK*

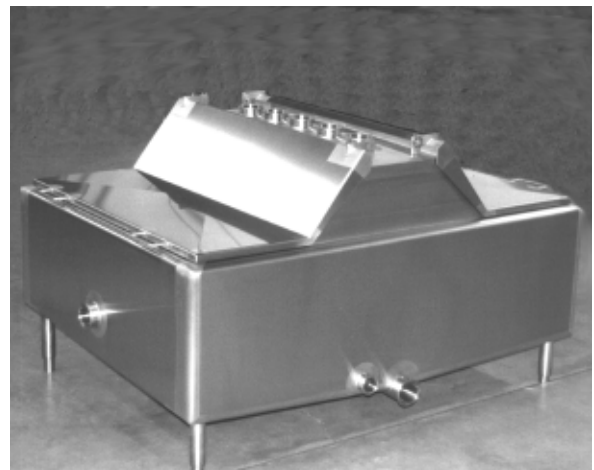
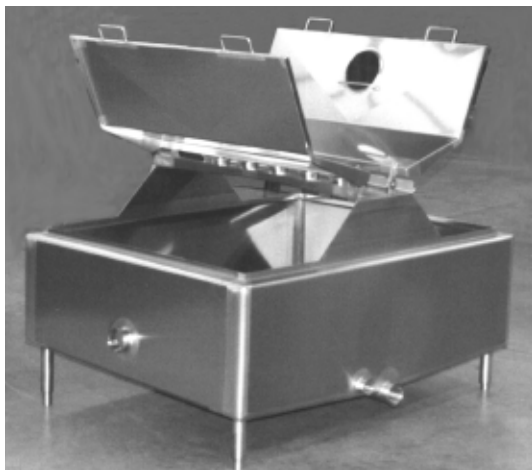

## STORAGE AND CIP TANKS

- ▶ T-304 or T-316L construction
- ▶ Fabricated as per your design
- ▶ S.S. adjustable legs
- ▶ Gasketed or ungasketed manways
- ▶ Welds polished to meet 3A standards
- ▶ Flat-flanged, cone, or dished heads
- ▶ Choice of 2B or #4 finish exterior and interior

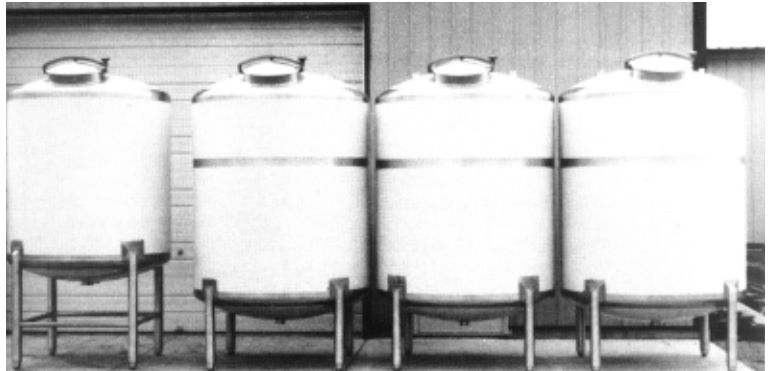

### *STORAGE TANK AND CONTROL CABINET*



### *STORAGE TANK WITH LADDER*



**1/4" KNUCKLE RADIUS FLAT FLANGE HEAD**

- ▶ 20ga – 7ga
- ▶ 12" – 96"
- ▶ + or – 1/16" Diameter Tolerances



**3/4" KNUCKLE RADIUS FLAT FLANGE HEAD**

- ▶ 12ga – 1/4" Plate
- ▶ 12" – 96"
- ▶ + or – 1/16" Diameter Tolerances



**3/4" KNUCKLE RADIUS 15 DEGREE CONE HEAD**

- ▶ 12ga – 7ga
- ▶ 20" – 96"
- ▶ + or – 1/8" Diameter Tolerances

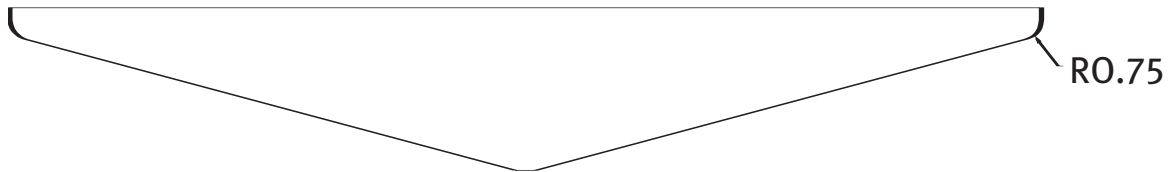

## BAFFLE PLATES/TUBE SHEETS

*Customize to your design*

*Available in Stainless Steel and Carbon Steel*

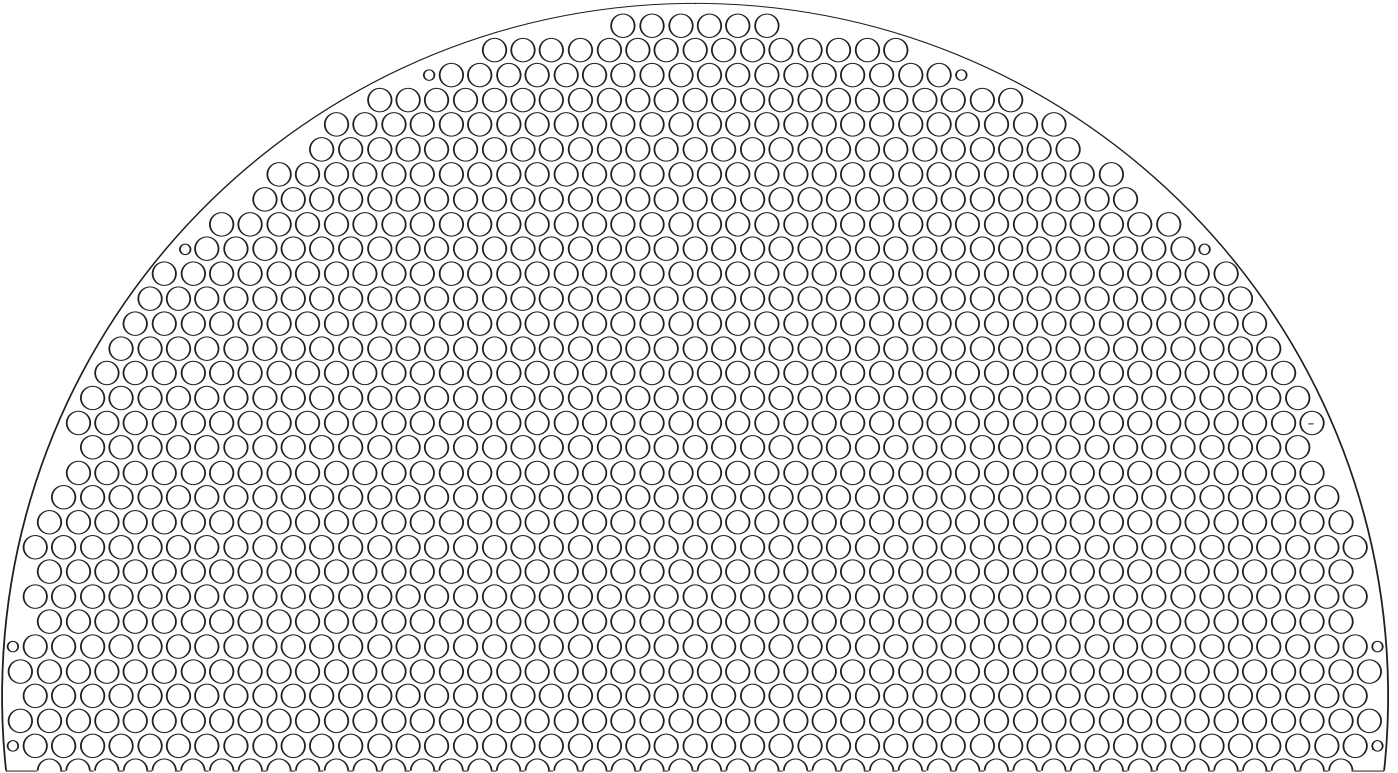

# FLOW PLATES

- ▶ Welds polished on front, seal welded and cleaned on back
- ▶ Constructed of either T-304 or T-316 S.S.
- ▶ Fabricated with tri-clamp, bevel seat or John Perry ferrules
- ▶ Constructed of 3/16" or 1/4" thick plate (as per your design)
- ▶ 1 1/2" bent lip on all four sides of plate
- ▶ 3" long butt weld tube or fitting on back
- ▶ Fabricated as per your design





**S.S. FLOW PLATES/VERTERS**

**TRI-CLAMP, BEVEL SEAT, AND JOHN PERRY FITTINGS**

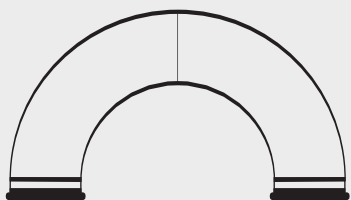

A

**TRI-CLAMP**

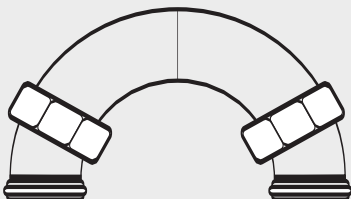

A

**BEVEL SEAT**

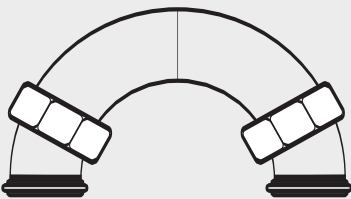

A

**JOHN PERRY**

**RETURN BENDS**

PORT SIZE	"A"
1 1/2"	4 1/2"
2"	6"
2 1/2"	7 1/2"
3"	9"
4"	12"

**4 PORT**

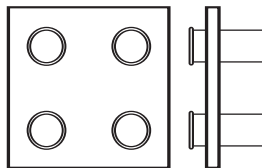

PORT SIZE	A
1 1/2"	11" x 11"
2"	12" x 12"
2 1/2"	14" x 14"
3"	16" x 16"
4"	20" x 20"

**4 PORT**

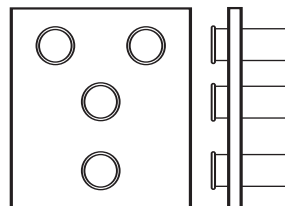

PORT SIZE	A
1 1/2"	14" x 14"
2"	16" x 16"
2 1/2"	18" x 18"
3"	21" x 21"
4"	27" x 27"

**5 PORT**

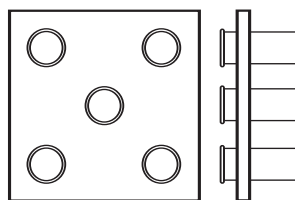

PORT SIZE	A
1 1/2"	14" x 14"
2"	16" x 16"
2 1/2"	18" x 18"
3"	21" x 21"
4"	27" x 27"

**6 PORT**

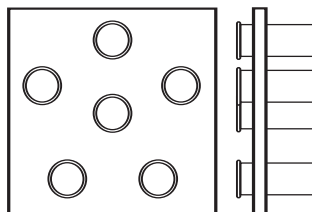

PORT SIZE	A
1 1/2"	15" x 15"
2"	18" x 18"
2 1/2"	21" x 21"
3"	24" x 24"
4"	30" x 30"

**7 PORT**

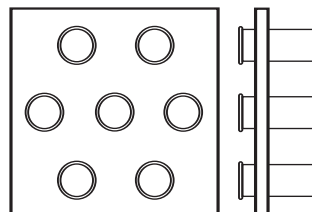

PORT SIZE	A
1 1/2"	15" x 15"
2"	18" x 18"
2 1/2"	21" x 21"
3"	24" x 24"
4"	30" x 30"

**9 PORT**

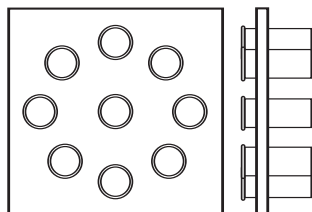

PORT SIZE	A
1 1/2"	15" x 15"
2"	18" x 18"
2 1/2"	21" x 21"
3"	24" x 24"
4"	30" x 30"

# ENCLOSURES

## NEMA - 4 S.S. CONTROL CABINETS

- ▶ Fabricated from 14 ga. or 12 ga. 304 S.S. with #4 finish on exterior
- ▶ .190 aluminum sub-panels
- ▶ Hinged and gasketed doors with three point roller ball assemblies, T-handles, twist clamps or 1/4 turn latches
- ▶ Instrument knockouts as per customers drawings



**ELECTRICAL ENCLOSURES**



- ▶ Fabricated to NEMA standards
- ▶ Sized to customer specs
- ▶ T-304 S.S. – 12, 14, or 16ga
- ▶ Polished O.D.
- ▶ Holes punched per customer specs



~ EXPANDED PRODUCT OFFERING ~

**JUNCTION BOXES**

- ▶ Increased product line

**DISCONNECT PANELS**

- ▶ Sizes up to 10 feet long

**SUB PANELS**

- ▶ Sizes and options coming soon

**CUSTOM CABINETS**

- ▶ Cabinets fabricated to your specs

**SLOPED TOP ENCLOSURES**

- ▶ Increased sanitation

**MOUNTING TABS**

- ▶ Available on all enclosures

~ ADDITIONAL OPTIONS ~

**LATCHES/HANDLES**

- ▶ Screw Clamp
- ▶ Twist Clamp
- ▶ “T” Handles
- ▶ “L” Handles
- ▶ 1/4 Turn Latches
- ▶ Three-point roller ball

**HINGES**

- ▶ Piano
- ▶ Tear-drop

## T-304 S.S. NEMA-1 JUNCTION BOXES

Other sizes available on request



	WITHOUT GASKET	WITH GASKET
SIZE	PART #	PART #
4" x 4" x 3" 16 ga	N1-443	N1-443CG
4" x 4" x 4" 16 ga	N1-444	N1-444CG
6" x 4" x 4" 16 ga	N1-664	N1-644CG
6" x 6" x 4" 16 ga	N1-664	N1-664CG
6" x 6" x 6" 16 ga	N1-666	N1-666CG
8" x 6" x 4" 16 ga	N1-864	N1-864CG
8" x 8" x 5" 16 ga	N1-885	N1-885CG
10" x 8" x 4" 16 ga	N1-1084	N1-1084CG
12" x 10" x 6" 16 ga	N1-12106	N1-12106CG
12" x 12" x 6" 16 ga	N1-12126	N1-12126CG
14" x 12" x 6" 16 ga	N1-14126	N1-14126CG
16" x 14" x 6" 16 ga	N1-16146	N1-16146CG

## T-304 S.S. NEMA-4x JUNCTION BOXES (HINGED & GASKETED)

Other sizes available on request



SIZE	PART #
4" x 4" x 3" 16 ga	N4-443
4" x 4" x 4" 16 ga	N4-444
6" x 4" x 4" 16 ga	N4-664
6" x 6" x 4" 16 ga	N4-664
6" x 6" x 6" 16 ga	N4-666
8" x 6" x 4" 16 ga	N4-864
8" x 8" x 5" 16 ga	N4-885
10" x 8" x 4" 16 ga	N4-1084
12" x 10" x 6" 16 ga	N4-12106
12" x 12" x 6" 16 ga	N4-12126
14" x 12" x 6" 16 ga	N4-14126
16" x 14" x 6" 16 ga	N4-16146

## T-304 S.S. NEMA-1 JUNCTION BOXES WITH MOUNTING TABS

Other sizes available on request



**Mounting Tabs**

	WITHOUT GASKET	WITH GASKET
SIZE	PART #	PART #
4" x 4" x 3" 16 ga	N1-443-MT	N1-443CG-MT
4" x 4" x 4" 16 ga	N1-444-MT	N1-444CG-MT
6" x 4" x 4" 16 ga	N1-664-MT	N1-644CG-MT
6" x 6" x 4" 16 ga	N1-664-MT	N1-664CG-MT
6" x 6" x 6" 16 ga	N1-666-MT	N1-666CG-MT
8" x 6" x 4" 16 ga	N1-864-MT	N1-864CG-MT
8" x 8" x 5" 16 ga	N1-885-MT	N1-885CG-MT
10" x 8" x 4" 16 ga	N1-1084-MT	N1-1084CG-MT
12" x 10" x 6" 16 ga	N1-12106-MT	N1-12106CG-MT
12" x 12" x 6" 16 ga	N1-12126-MT	N1-12126CG-MT
14" x 12" x 6" 16 ga	N1-14126-MT	N1-14126CG-MT
16" x 14" x 6" 16 ga	N1-16146-MT	N1-16146CG-MT

## T-304 S.S. NEMA-4x JUNCTION BOXES (HINGED & GASKETED) WITH MOUNTING TABS

Other sizes available on request



**Mounting Tabs**

SIZE	PART #
4" x 4" x 3" 16 ga	N4-443-MT
4" x 4" x 4" 16 ga	N4-444-MT
6" x 4" x 4" 16 ga	N4-664-MT
6" x 6" x 4" 16 ga	N4-664-MT
6" x 6" x 6" 16 ga	N4-666-MT
8" x 6" x 4" 16 ga	N4-864-MT
8" x 8" x 5" 16 ga	N4-885-MT
10" x 8" x 4" 16 ga	N4-1084-MT
12" x 10" x 6" 16 ga	N4-12106-MT
12" x 12" x 6" 16 ga	N4-12126-MT
14" x 12" x 6" 16 ga	N4-14126-MT
16" x 14" x 6" 16 ga	N4-16146-MT

T-304 S.S. SLOPED TOP ENCLOSURES

**Fabricated to your specifications**



*Slope Top enclosures offer increased sanitation over traditional enclosures when used in wet and corrosive environments.*

SUB PANELS

**Fabricated to your specifications**



**SUB PANELS**

- ▶ Aluminum
- ▶ Galvanized
- ▶ Stainless Steel
- ▶ Steel (powder coated)

# LASER DIVISION

## About Us

**AWI Laser**, a division of AWI Manufacturing, was initially formed out of a desire to more efficiently serve our current customers' laser cutting and metal fabrication needs. As the demand for these services grew, we expanded to meet the needs of new customers as well. Instead of you shipping parts from shop to shop for multiple processes, we've brought them under one roof to meet your multiple process needs. Our current customers have appreciated the simplicity and high quality they get with AWI Laser, and we know you will too.

From start to finish, you can count on AWI Laser to act as an extension of your factory. We will never be the weak link in your process. Starting with quick and accurate custom manufacturing quotes — we won't leave you waiting for answers. We will follow up with you throughout the manufacturing process so you never wonder where your order is. We fit into your *Just-In-Time* delivery schedules and can produce parts to meet your deadlines. We will provide the documentation you need and you can be assured there will be no unpleasant surprises when your project is complete. Quality is the number one job of all employees at AWI Laser, which means you never receive an inferior product.

We have what it takes to get your job done. Our 5000-watt lasers cut thicker materials at high speeds; while maintaining tight tolerances for all types of metals. We also provide metal fabrication services including, machining, welding, and forming. You never miss a deadline because of costly multiple shipments. We apply our years of experience to your project and find the most efficient processes that get your product to you fast. We know how to anticipate and solve problems before your project even begins — finding opportunities for improvement that have a positive impact on your bottom line. We base our process on your project to ensure you have a solution that works — there's no cookie-cutter approach here.

Find out what AWI Laser can do for you: request a quote or contact us today.

# AWI MANUFACTURING FACILITY INFORMATION

(80,000 Sq. Ft. Manufacturing Floor Space)

## LASER CUTTING

---

- ▶ BLM Group Adige LaserTube LT 8
  - Round Tube: min. diameter .5" – max. 8.625"
  - Square Tube: min. diameter .5" – max. 8"
  - Rectangular Tube: min. width .5" – max. width 8"
- ▶ 5000 Watt Trumpf Laser Cutters
  - 7' X 13' Table Size
  - 1-1/4" Mild Steel
  - 1" Stainless Steel
  - 3/4" Aluminum
  - 3/8" Titanium and Brass

## SHEARING

---

- ▶ 1/2" X 12' Shear
- ▶ 1/4" X 10' Shear
- ▶ 3/8" X 12' Circle Shear

## WELDING

---

- ▶ 12' Seam Welder
- ▶ Spot Welder
- ▶ (4) Mig Welding Machines
- ▶ (22) Tig Welding Machines

## MACHINING

---

- ▶ CNC Vertical Mill Machining Center
- ▶ 66 Ton Ironworker
- ▶ (2) Bridgeport Mills
- ▶ 15" X 48" Gap Lathe

## FORMING

---

- ▶ 190 Ton Press Brake w/CNC Backgauge - 12'
- ▶ 175 Ton Press Brake w/CNC Backgauge - 10'
- ▶ 135 Ton Press Brake - 12'
- ▶ 60 Ton Press Brake w/CNC Backgauge - 8'

## ROLLING

---

- ▶ 1/4" X 12' Roller
- ▶ 1/4" X 5' Roller
- ▶ 10 Gauge x 3' Roller

## PUNCHING/STAMPING

---

- ▶ 75 Ton Punch Press OBI
- ▶ 88 Ton Punch Press OBI
- ▶ 35 Ton Punch Press OBI

## OTHER

---

- ▶ State-of-the-Art Material Nesting
- ▶ 3/8" X 12' Head Flanger
- ▶ Automatic Feed Bandsaw
- ▶ Surface Grinder
- ▶ Skin Packaging Machine
- ▶ Sand Blast Booth
- ▶ 50 HP Screw Air Compressor





**AWI MANUFACTURING**

**320.485.2471 | fax 320.485.4466**

**Shipping: 3902 230th Street, Winsted, MN 55395 USA | Mailing: P.O. Box 909, Winsted, MN 55395-0909 USA**

**[www.awimfg.com](http://www.awimfg.com)**